

Model 612AV

Mass Flow Controller

aerospace
climate control
electromechanical
filtration
fluid & gas handling
hydraulics
pneumatics
process control
sealing & shielding

Porter's Model 612AV Series II Mass Flow Controller (MFCs) is designed for precise control of virtually all conventional process gases. The MFC consists of a thermal mass flow sensor, a precise control valve and a microprocessor based PID controller with signal and fieldbus conversion. Based on the setpoint input value, the flow controller swiftly adjusts to the desired flow rate. The mass flow rate is provided as analog signal or digitally via RS232 or various fieldbus options. Each unit is specifically sized and calibrated depending on the types of gas and the process conditions of the application.



Product Features:

- Full Scale Flow Ranges from 40 l/min to 250 l/min
- Operating Pressures up to 1450 PSIA
- High accuracy and repeatability
- Storage of max. 8 calibration curves
- User configurable control characteristics
- Flow Parameter Adjust functionality up to 150 PSIA
- Effective Rangeability <math><180:1</math>
- Analog or digital: RS232, DeviceNet™, ProfibusDP®, Modbus-RTU

500/600 Series II Flowmeter Products

Thermal Mass Flow Measuring Principle

The Mass Flow Sensing System consists of a stainless steel capillary tube with two precision heater and temperature sensing elements wound around the outside of the tube. As gas flows through the capillary tube, heat is displaced to the downstream temperature sensor creating a differential between the two sensors. The difference is directly proportional to mass flow through the tube. In the main flow channel, a patented laminar flow element package creates a restriction that forces a fixed percentage of the total flow through the sensor for temperature differential detection.

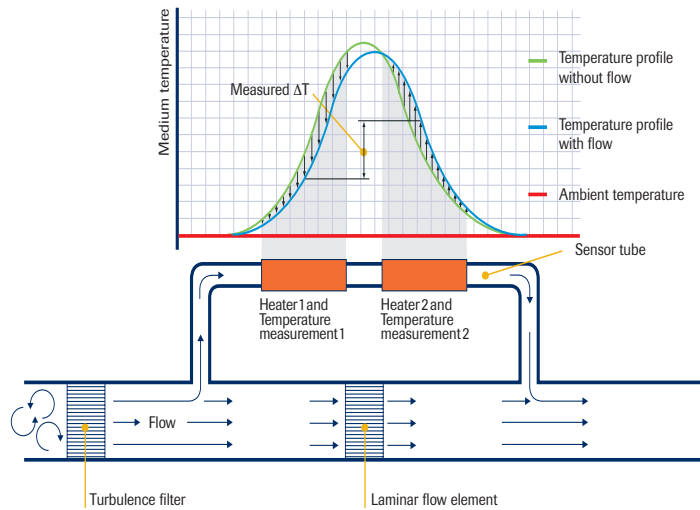

$$\Delta T = k \cdot C_p \cdot \dot{Q}_m \quad \Delta T = T_2 - T_1 \text{ in Kelvin} \quad C_p = \text{specific heat} \quad \dot{Q}_m = \text{mass flow}$$

State of the Art Digital Design

Porter's Series II Mass Flow products are equipped with a microprocessor based digital pc-board offering high accuracy, excellent temperature stability and fast MFC response time. The basic digital pc-board contains all of the general functions needed for measurement and control. RS232 communication and analog I/O are included. An optional integrated communication interface board provides DeviceNet™, Profibus-DP® or Modbus-RTU.

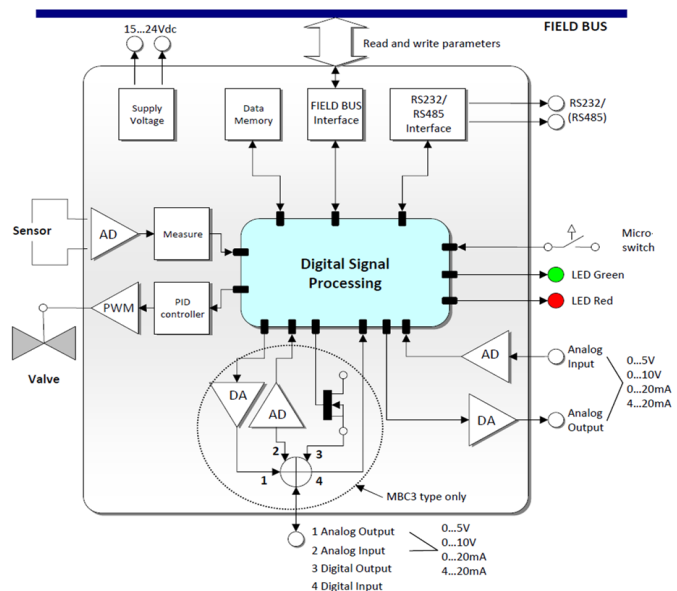

Models and Flow Ranges

Model	Minimum	Nominal	Maximum
612AV - S	0.8 to 40 l/min	0.8 to 100 l/min	0.8 to 150 l/min
612AV - T	1.4 to 70 l/min	1.4 to 200 l/min	1.4 to 250 l/min

All flow ranges are at standard conditions of 14.7 PSIA and 70°F (21.1°C)

Specifications

Measurement / Control System

Accuracy (incl. linearity) (based on actual calibration)	Standard: $\pm 0.5\%$ Reading plus $\pm 0.1\%$ Full Scale
Turndown	1 : 50 (in digital mode up to 1 : 187.5)
Repeatability	<0.2% Reading
Settling Time (Controller)	Standard: 2-4 seconds
Control Stability	< $\pm 0.1\%$ Full Scale (typical for 1 l/min N ₂)
Operating Temperature	-10 to +70°C
Temperature Sensitivity	Zero: <0.05% Full Scale/°C; span: <0.05% Reading/°C
Pressure Sensitivity	0.1%/ATM typical N ₂ ; 0.01%/ATM typical H ₂
Leak Integrity, outboard	Tested < 2 x 10 ⁻⁹ mbar l/s He
Attitude Sensitivity	Max. error at 90° off horizontal 0.2% at 1 ATM, typical N ₂
Warm-Up Time	30 min. for optimum accuracy 2 min. for accuracy $\pm 2\%$ Full Scale

Mechanical Parts

Material (wetted parts)	Stainless steel 316L or equivalent
Surface Quality (wetted parts)	Ra= 0.8µm typical
Process Connections	Compression or face seal fittings
Seals	Standard: Viton Options: EPDM, Kalrez (FFKM)
Ingress Protection (housing)	IP40

Electrical Properties

Power Supply	+15-24 Vdc
Power Consumption	Meter: 70 mA; Controller: max. 320 mA; Add 50 mA for Profibus, if applicable
Analog Output/Command	0-5 (10) Vdc or 0 (4)-20 mA - specify - (Sourcing output)
Digital Communication	Standard: RS232 Options: Profibus-DP®, DeviceNet™, EtherCAT®, Modbus

Electrical Connection

Analog/RS232	9-pin D-connector (male)
Profibus-DP®	Bus: 9-pin D-connector (female) Power: 9-pin D-connector (male)
DeviceNet™	5-pin M12-connector (male)
EtherCAT®	2 x RJ45 modular jack (in/out)
Modbus-RTU/FLOW-BUS	RJ45 modular jack

Technical specifications and dimensions subject to change without notice.

Dimensions

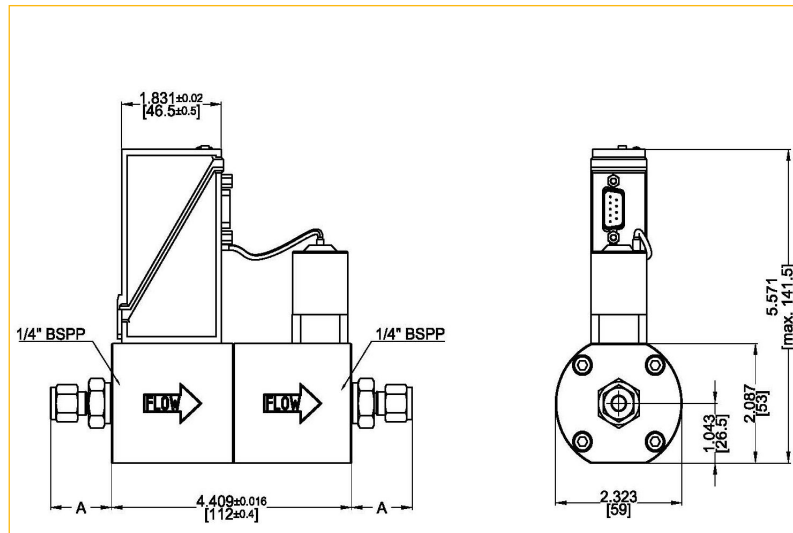

Bracket = Millimeters

1/4" BSPP	
Compression	Size A
Fitting 6 mm OD	1.118 (28.4)
Fitting 8 mm OD	1.157 (29.4)
Fitting 10 mm OD	1.189 (30.2)
Fitting 12 mm OD	1.280 (32.5)
Fitting 1/4" OD	1.118 (28.4)
Fitting 3/8" OD	1.177 (29.9)
Fitting 1/2" OD	1.287 (32.7)
Face-Seal Male	
Size A	
Fitting 1/4" inlet	0.913 (23.2)

(Millimeters)

Ordering Information

6 1 2AV S A A A 22 A

Base	
6	Controller
Pressure Rating	
1	1450 PSIA
Ranges	
2AV	0 to 40 / 0 to 250 l/min
Nominal Range	
Factory Selected	
Communication (I/O)	
A	RS232 + analog (n/c control)
B	RS232 + analog (n/o control)
D	RS232 + DeviceNet (n/c)
E	RS232 + DeviceNet (n/o)
M	RS232 + Modbus-RTU (n/c)
N	RS232 + Modbus-RTU (n/o)
P	RS232 + Profibus -DP (n/c)
Q	RS232 + Profibus - DP (n/o)
R	RS232 + FLOW-BUS (n/c)
S	RS232 + FLOW-BUS (n/o)
Internal Seals	
V	Viton (Factory Standard)
E	EPDM
K	Kalrez (FFKM)
Connections (in/out)	
2	1/4" OD Compression
3	6 mm OD Compression Type
4	12 mm OD Compression Type
5	1/2" OD Compression Type
8	1/4" Face Seal Male
9	Other
0	None
Supply Voltage	
D	+15 to 24 Vdc
Analog Output	
A	0 to 5 Vdc
B	0 to 10 Vdc
F	0 to 20 mA Sourcing
G	4 to 20 mA Sourcing

Hook-up Diagram for Analog or RS232 Communication

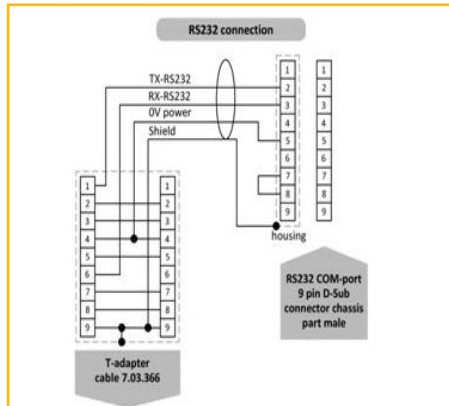

Note: Pin 4 and Pin 8 should be separately and connected to power common at the power supply.

Note: When using a unit configured for a fieldbus or RS232 I/O, it is not possible to operate the instrument using analog I/O without changing the "control mode" parameter. (See users manual)

Note: For hookup details of modbus, Profibus or DeviceNet communications, see users manual.

Note: Do not connect external valve to instruments configured as flow meters

Note: Valve out signal is 0 - 10 Vdc, .1mA

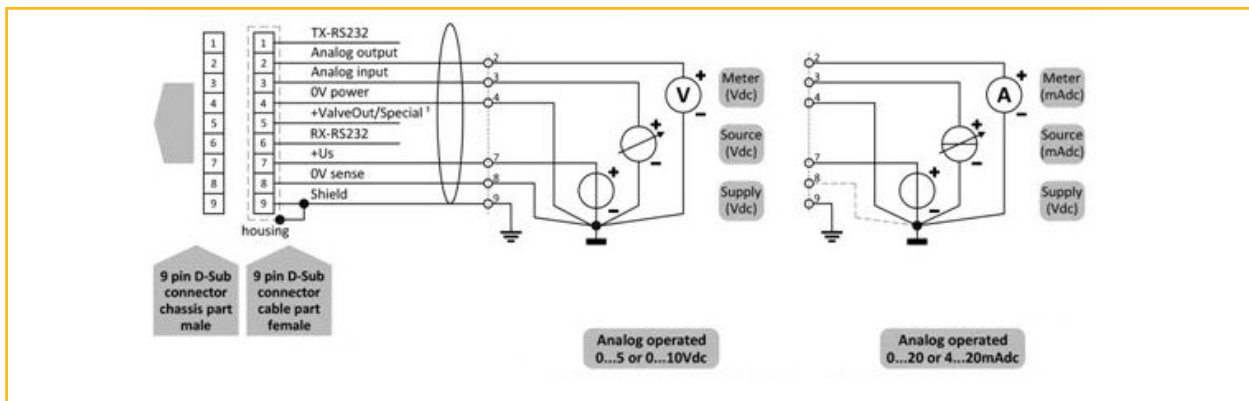
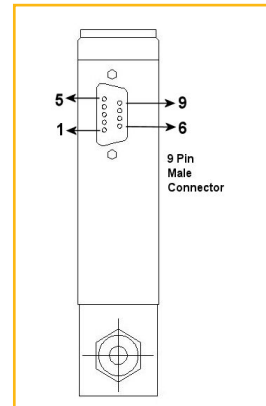

⚠ WARNING – USER RESPONSIBILITY

FAILURE OR IMPROPER SELECTION OR IMPROPER USE OF THE PRODUCTS DESCRIBED HEREIN OR RELATED ITEMS CAN CAUSE DEATH, PERSONAL INJURY AND PROPERTY DAMAGE.

This document and other information from Parker-Hannifin Corporation, its subsidiaries and authorized distributors provide product or system options for further investigation by users having technical expertise.

The user, through its own analysis and testing, is solely responsible for making the final selection of the system and components and assuring that all performance, endurance, maintenance, safety and warning requirements of the application are met. The user must analyze all aspects of the application, follow applicable industry standards, and follow the information concerning the product in the current product catalog and in any other materials provided from Parker or its subsidiaries or authorized distributors.

To the extent that Parker or its subsidiaries or authorized distributors provide component or system options based upon data or specifications provided by the user, the user is responsible for determining that such data and specifications are suitable and sufficient for all applications and reasonably foreseeable uses of the components or systems.

Offer of Sale

The items described in this document are hereby offered for sale by Parker-Hannifin Corporation, its subsidiaries or its authorized distributors. This offer and its acceptance are governed by the provisions stated in the detailed "Offer of Sale" elsewhere in this document or available at www.parker.com/offerofsale.

WS-0036 Rev. 0 5/14

Parker Hannifin Corporation
Porter Instrument Division
 245 Township Line Road
 Hatfield, PA 19440

phone 215 723 4000
 fax 215 723 2199
industrial@parker.com

www.parker.com/porter



ENGINEERING YOUR SUCCESS.